



performance proven **VACUUM SOLUTIONS™**

VecLoader Vacuums for Mining Vacuum Truck Power with Unique Operating Advantages

VECLOADER®

INDUSTRIAL VACUUM LOADERS

Conveyor Spills
Housekeeping

Varied Designs for Varied
Customer Requirements.



Vector Technologies offers a complete line of high powered VecLoader vacuums for the recovery of mining fines, dust and similar bulk product. VecLoader systems are offered in a wide range of diesel and electric powered configurations. Potential uses include general house-keeping, crushing house cleaning, conveyor spill recovery, bulk transfers between storage vessels, and railcar or barge unloading, as well as cleaning at conveyor transfer points or yard and tunnel cleaning. The unique design of Vector vacuums allows for both wet and dry materials recovery without changeover. Modular designs can be matched to varied requirements and most enhancements can be easily accommodated. Recovered materials can be loaded into dump trucks, dumpsters, and gaylords or even back onto conveyors or into positive pressure conveyance systems.

The VecLoader Titan's 28" Hg vacuum allows great job flexibility when conveying longer distances, as far as 1,000 feet. Vector self-pulsing baghouses represent thirty years of proven safety and performance. Regardless of power and configuration, each VecLoader model is easily maintained and simple to use, without complicated set-up. VecLoader vacuums are available with premium grade silencers and product specific filtration. Sound levels on electric models can be attenuated to less than 80 to 85 dBA.

DELIVERING MORE EFFICIENCY, FLEXIBILITY AND POWER

VECTOR TECHNOLOGIES LTD. / VACUUM ENGINEERING GROUP/ ROSS COOK BRAND

6820 North 43rd Street/ Milwaukee, WI USA

Phone: 1 414 247-7100/ Fax: 1 414 247-7110/ E-Mail: sales@vector-vacuums.com/ Website: www.vector-vacuums.com

Industrial Vacuum Systems · Hydro Blast Recovery Systems · Dust Collectors · Classifiers · Blast and Recovery Systems
Equipment Sales · Parts · Rentals · Service · Solutions



performance proven **VACUUM SOLUTIONS™**

VECTOR TECHNOLOGIES LTD. AND ITS VACUUM ENGINEERING GROUP AND ROSS COOK BRANDS are leading designers and manufacturers of industrial vacuums, abrasive blast and surface preparation equipment, portable dust collectors and baghouses, asbestos and hazardous waste removal equipment, and other conveyance products for hazardous and non-hazardous material handling. Vector designs have set world standards for reliability and performance in a variety of general industrial and specialized markets. Good listening, creative ideas, expert design, quality manufacturing, extensive field tests, and overall responsiveness to customers have helped Vector maintain its position of leadership since 1977. The employees of Vector take great pride in offering dependable, long lasting world-class products at competitive prices.

Vector provides benefits far beyond building the best equipment. Experienced in-field service personnel, local support, extensive parts inventories and a 24-hour assistance line assure readily available technical support. Services include specialized system design, engineering and supplying of central manifold systems, start-up training, preventive maintenance programs, field repairs, and continuing customer education. Additionally, Vector can assist with machine financing and leasing programs.

PRODUCTS

- Central Vacuum Systems
- Mobile Industrial Vacuums
- Vacuum Excavators for Horizontal Directional Drilling
- Combination Vacuum and Jetter Systems
- Cyclonic Baghouses/ Intermediate Separators
- Dust Collectors/ Baghouses
- Abrasive Blasting/ Classifying Equipment
- Asbestos and Hazardous Waste Removal Equipment

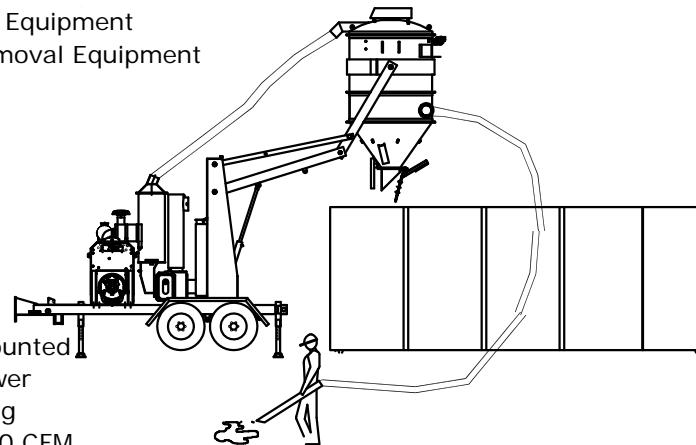
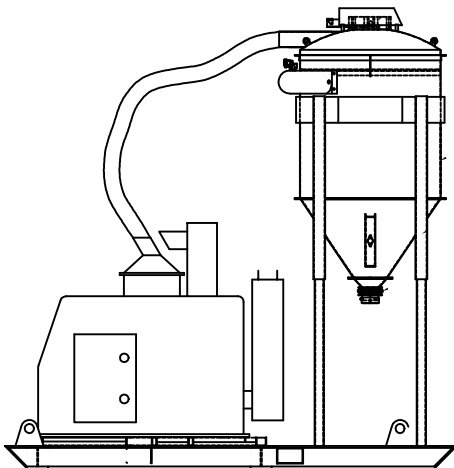

CONFIGURATIONS

- Trailer, central, skid or truck mounted
- Vacuums: 5 to 500 Horsepower
- 300 to 6,000 CFM/ to 28" Hg
- Dust Collectors: 5,000 to 60,000 CFM
- Electric, diesel, gas, and liquid propane powered

INDUSTRIES

Mining	Surface Preparation	Hydro Blasting	Steel Mills	Aerospace
Wood/Paper/Pulp	Vacuum Excavation	Power Plants	Chemicals	Clean Room
Primary Metals	Site Remediation	Shipbuilding/Repair	Glass	Powder Coating
Nuclear/Asbestos	General Industrial	Foundry	Chip & Wafer	Waste Water
Spill Recovery	Brick/Refractory	Emergency Response	Roofing	Bulk Material
Baking	Hazardous Waste	Industrial Cleaning	Cement	Plastics
Carbon	Sewer Cleaning	Railroad Car Cleaning	Catalyst	Pharmaceutical

REPRESENTATIVE CUSTOMERS

Ford Motor, Boeing, Lafarge, Northrop Grumman, Lockheed-Martin, Halliburton, Cat-Tech, General Electric, Eastman Kodak, Bechtel, Bristol Myers, IBM, General Motors, Philip Morris, Rockwell, Owens Corning, U.S. Depts. of Army, Air Force, Navy, U.S. Dept. of Energy, Boise Cascade, Carnegie Mellon, Cargil, Exxon Mobil, Hewlett Packard, International Paper, Johnson Controls, Kerr McGee, Newport News Shipbuilding, Proctor & Gamble, Lawrence Livermore, Oakridge, and Los Alamos National Labs, Textron, Tenneco, U. S. Steel, U. S. Generating, Intel, DuPont, Kerr-McGee, General Dynamics, General Mills, Kimberly-Clark, Nabisco, Pillsbury, 3M, Toyota, Honda, Xerox, Alcoa.

VECTOR TECHNOLOGIES LTD. / VACUUM ENGINEERING GROUP/ ROSS COOK BRAND

6820 North 43rd Street/ Milwaukee, WI USA

Phone: 1 414 247-7100/ Fax: 1 414 247-7110/ E-Mail: sales@vector-vacuums.com/ Website: www.vector-vacuums.com



performance proven **VACUUM SOLUTIONS™**

VecLoader Vacuums for Mining Vacuum Truck Power with Unique Operating Advantages

Model 616 HP: Partially Raised



Model 624: Stowed/travel Position



VECLOADER®
**TRAILER
MOUNTED**
HIGH-POWERED
INDUSTRIAL
VACUUM LOADERS
Wet or Dry Recovery

Model 721: Working



Model 721: Dump Truck Loading



More Power!

**Better
Performance!**

Proven Solutions!

For Mining, Vector Technologies offers a complete line of High Mercury VecLoader Titan vacuums. The Titan 28" Hg vacuum provide the greatest flexibility when conveying longer distances or handling dense waste streams such as gold or copper dust sand fines, ore or slurries. The VecLoader self-pulsing baghouse represents a thirty year legacy of proven safety and performance. Regardless of power and configuration, each VecLoader model is simple to use without complicated set-up and easily maintained. All VecLoader units are available with premium grade silencers. Electric Models can be attenuated to under 85 dBA where beneficial.

Use as stand alone systems or combine with baghouses for proven performance for—
Conveyor Spills ~ Crusher House Cleaning ~ Product Recovery
Material Transport ~ Filter Beds Cleaning ~ Improved Air Quality

Call 1 414.247.7100 or U.S. Toll Free 1 800.832.4010

DELIVERING MORE EFFICIENCY, FLEXIBILITY AND POWER

Vector Technologies Ltd./ Vacuum Engineering Division/ 6820 N. 43rd Street/ Milwaukee WI USA 53209

Toll Free: 1 800 832 4010/ Tel: 1 414 247 7100/ Fax: 1 414 247 7110
Web Site: www.vector-vacuums.com/ E-Mail: sales@vector-vacuums.com



616 can be towed with a "One-Ton"



Model 721 with Optional Hi-Lift™



Model 624 over Dump Truck

VECLOADER® VACUUMS

Models	Mini-VecLoader 100	616 HP	624	721	1021R
Maximum CFM/Hg	1,340/28"	2,367/28"	3,510/16"	3,660/28"	6,150/28"
Horsepower	100	170	155	235	350
Primary Filtration	Coated bags pulse air cleaned	Coated bags pulse air cleaned	Coated bags pulse air cleaned	Coated bags pulse air cleaned	Coated bags pulse air cleaned
Secondary Filtration	Pleated cartridge	Pleated cartridge	Pleated cartridge	Pleated cartridge	Pleated cartridge
Maximum Hose Diameter	4"	5"	6"	6"	6"
Dimensions (L, W, H)	16' 1", 7' 2", 10' 0"	17' 5", 8' .5", 11' 2.5"	17' 5", 8' .5", 11' 2.5"	21'0", 8' 2.5", 11' 4"	24'10", 8' 4.0", 11' 4"
Empty Weight	8,100#	10,500#	10,500#	13,950#	22,350#
Maximum Conveying	1,200'	1,200'	600'	1,200'	1,200'
Maximum Performance/Bulk	8 tons/hr.	15 tons/hr.	18 tons/hr.	23 tons/hr.	28-35 tons/hr.
Maximum Performance/Liquid	100 gallons/min.	300 gallons/min.	325 gallons/min.	425 gallons/min.	600 gallons/min.

* Performance figures are averages based on easily conveyed products at shorter distances. Many factors will affect vacuum productivity.

Options and Alternative Designs:

Power: Diesel, electric, explosion resistant. **Mounting:** Road legal trailer, all terrain, skid, truck, and crane.

Unloader valves: Double dump, gravity, rotary airlock, and specialty valves. **Filtration:** HEPA, nuclear, carbon, product specific.

Accessories: Cyclone drum fillers, intermediate hoppers and separators, bagging stations, vacuum hose, specialty nozzles, and engineered solutions.

VecLoaders are extremely powerful and compact vacuum systems, incorporating innovative technology to solve a wide range of industrial vacuuming and conveyance needs. They move coal, ash, dirt, blast media, sand, stone, water, slurry and other flowable bulk materials utilizing either four, five or six inch diameter hose or multiple smaller diameter hoses. Modular in design, VecLoaders can be easily matched to a broad assortment of customer specified cyclone separators, filter-receivers, collections systems, classifiers, self-dumping hoppers and intermediate collection devices. Specifications subject to change without notice so that improvements are made as quickly as possible.

Call 1 414.247.7100 or U.S. Toll Free 1 800.832.4010

DELIVERING MORE EFFICIENCY, FLEXIBILITY AND POWER

Vector Technologies Ltd./ Vacuum Engineering Division/ 6820 N. 43rd Street/ Milwaukee WI USA 53209

Toll Free: 1 800 832 4010/ Tel: 1 414 247 7100/ Fax: 1 414 247 7110
 Web Site: www.vector-vacuums.com/ E-Mail: sales@vector-vacuums.com

Vacuums · Hydro Blast Systems · Dust Collectors · Vacuum Excavation Systems · Classifiers ·
 Blast and Recovery Systems · Vacuum /Jetter Combinations · Spill Response Systems · Parts · Rentals · Service · Solutions