



performance proven **VACUUM SOLUTIONS™**

Vac Attack for Powders and Bulk Products!

VECLOADER® INDUSTRIAL VACUUM SYSTEMS

For Bulk Product Recovery

**Varied Designs for Varied
Needs.**



Vector Technologies offers a complete line of high powered VecLoader vacuums for the recovery of cement, gypsum, Ready-Mix concrete and similar bulk product. VecLoader systems are offered in a wide range of diesel and electric powered configurations. Potential uses include general house-keeping, spill recovery, bulk transfers between storage vessels, railcar and barge unloading and final clean-up, as well as cleaning at conveyor transfer points or yard and tunnel cleaning. The unique design of Vector vacuums allows for both wet and dry materials recovery without changeover. Modular designs can be matched to varied requirements and most enhancements can be easily accommodated. Recovered materials can be loaded into dump trucks, dumpsters, and gayloads or even back onto conveyors or into positive pressure conveyance systems.

The VecLoader Titan's 28" Hg vacuum allows great job flexibility when conveying longer distances, as far as 1,000 feet. Vector self-pulsing baghouses represent thirty years of proven safety and performance. Regardless of power and configuration, each VecLoader model is easily maintained and simple to use, without complicated set-up. VecLoader vacuums are available with premium grade silencers and product specific filtration. Sound levels on electric models can be attenuated to less than 80 to 85 dBA.

DELIVERING MORE EFFICIENCY, FLEXIBILITY AND POWER

Vector Technologies Ltd./ Vacuum Engineering Division/ 6820 N. 43rd Street/ Milwaukee WI USA 53209

Toll Free: 1 800 832 4010/ Tel: 1 414 247 7100/ Fax: 1 414 247 7110

Web Site: www.vector-vacuums.com/ E-Mail: sales@vector-vacuums.com

Industrial Vacuum Systems · Hydro Blast Recovery Systems · Dust Collectors · Classifiers · Blast and Recovery Systems
Equipment · Parts · Rentals · Service · Solutions



performance proven **VACUUM SOLUTIONS™**

VECTOR TECHNOLOGIES LTD. AND ITS VACUUM ENGINEERING GROUP AND ROSS COOK BRANDS

are leading designers and manufacturers of industrial vacuums, abrasive blasting and surface preparation equipment, portable dust collectors and baghouses, asbestos and hazardous waste removal equipment, and other conveyance products for hazardous and non-hazardous material handling. Established in 1977, Vector designs have set world standards for reliability and performance in a variety of industrialized and specialized markets. With good listening, creative ideas, expert design, quality manufacturing, extensive field tests, and responsive service, Vector maintains its position of leadership. The employees of Vector take great pride in offering dependable, long lasting world-class products at competitive prices.

Vector provides benefits far beyond building the best equipment. Experienced in-field service personnel, extensive parts inventories and a 24-hour assistance line assure readily available technical support. Services include specialized system design, engineering and supplying of central manifold systems, start-up training, preventive maintenance programs, field repairs, and continuing customer education. Additionally, Vector can assist with machine financing and leasing programs.

PRODUCTS

- Central Vacuum Systems
- Mobile Industrial Vacuums
- Vacuum Excavators for Horizontal Directional Drilling
- Combination Vacuum and Jetter Systems
- Cyclonic Baghouses/ Intermediate Separators
- Dust Collectors/ Baghouses
- Abrasive Blasting/ Classifying Equipment
- Asbestos and Hazardous Waste Removal Equipment

CONFIGURATIONS

- Trailer, central, skid or truck mounted
- Vacuums: 5 to 500 Horsepower
- 300 to 6,000 CFM/ to 28" Hg
- Dust Collectors: 5,000 to 60,000 CFM
- Electric, diesel, gas, and liquid propane powered

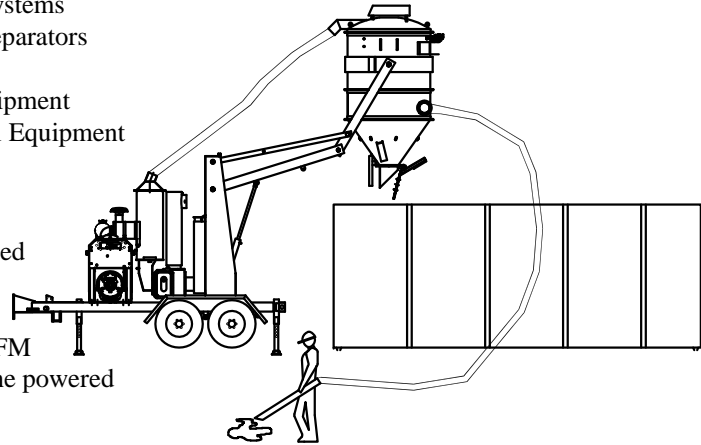
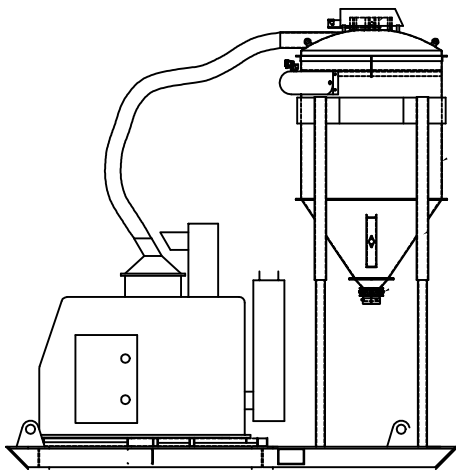

INDUSTRIES

Mining	Surface Preparation	Hydro Blasting	Steel Mills	Aerospace
Wood/Paper/Pulp	Vacuum Excavation	Power Plants	Chemicals	Clean Room
Primary Metals	Site Remediation	Shipbuilding/Repair	Glass	Powder Coating
Nuclear/Asbestos	Industrial Vacuum Cleaning	General Industrial	Foundry	Chip & Wafer
Spill Recovery	Brick/Refractory	Emergency Response	Roofing	Baking
Bulk Material	Hazardous Waste	Waste Water	Cement	Plastics
Carbon	Sewer Cleaning	Railroad Car Cleaning	Catalyst	Pharmaceutical

REPRESENTATIVE CUSTOMERS

Ford Motor, Boeing, Northrop Grumman, Lockheed-Martin, Halliburton, Cat-Spec, General Electric, Dupont, Eastman Kodak, Bechtel, Bristol Myers, IBM, General Motors, Philip Morris, Rockwell International, Owens Corning, U.S. Depts. of Army, Air Force, Navy, U.S. Dept. of Energy, Boise Cascade, Carnegie Mellon, Cargil, Exxon, Hewlett Packard, International Paper, Johnson Controls, Kerr McGee, Newport News Shipbuilding, Proctor & Gamble, Lawrence Livermore, Oakridge, and Los Alamos National Labs, Textron, Tenneco, U. S. Steel, U. S. Generating, Kerr-McGee, General Dynamics, Dupont, General Mills, Kimberly-Clark, Nabisco, Pillsbury, 3M, Toyota, Honda, Xerox, Alcoa.

VECTOR TECHNOLOGIES LTD. / VACUUM ENGINEERING GROUP/ ROSS COOK BRAND

6820 North 43rd Street/ Milwaukee, WI USA

Toll Free: 1 800 832-4010/ Phone: 1 414 247-7100

Fax: 1 414 247-7110/ E-Mail: sales@vector-vacuums.com/ Website: www.vector-vacuums.com

Vacuums · Hydro Blast Systems · Dust Collectors · Vacuum Excavation Systems · Classifiers · Blast and Recovery Systems · Vacuum /Jetter Combinations · Spill Response Systems · Parts · Rentals · Service · Solutions