



performance proven **VACUUM SOLUTIONS™**

VECLOADER®

INDUSTRIAL VACUUM LOADERS

For Cement and Similar Bulk Product Recovery

Varied Designs for Varied Customer Requirements.



Vector Technologies offers a complete line of high powered VecLoader vacuums for the recovery of cement, gypsum, Ready-Mix concrete and similar bulk product. Systems are available in diesel, liquid propane and electric powered designs. Typical uses include general house-keeping, spill recovery, bulk transfers between storage vessels, railcar and barge unloading and final clean-up, as well as cleaning at conveyor transfer points or yard and tunnel cleaning. The unique design of Vector vacuums allows for both wet and dry materials recovery without changeover. Modular components can be matched to varied customer requirements with special customer requirements easily accommodated. Recovered materials can be loaded into dump trucks, dumpsters, and gaylords or back onto conveyors or into positive pressure conveyance systems.

The VecLoader Titan's 28" Hg vacuum allows great job flexibility when conveying longer distances, as far as 1,000 feet. Vector self-pulsing baghouses represent thirty years of proven control, safety and performance. Regardless of power and configuration, each VecLoader model is easily maintained and simple to use, without complicated set-up. VecLoader vacuums are available with premium grade silencers, sound packages and product specific filtration, including nuclear and Hepa filtration. Sound levels on many models can be attenuated to less than 85 dBA.

DELIVERING MORE EFFICIENCY, FLEXIBILITY AND POWER

VECTOR TECHNOLOGIES LTD. / VACUUM ENGINEERING GROUP/ ROSS COOK BRAND

6820 North 43rd Street/ Milwaukee, WI USA

Phone: 1 414 247-7100/ Fax: 1 414 247-7110/ E-Mail: sales@vector-vacuums.com/ Website: www.vector-vacuums.com

**Industrial Vacuum Systems · Hydro Blast Recovery Systems · Dust Collectors · Classifiers · Blast and Recovery Systems
Equipment Sales · Parts · Rentals · Service · Solutions**



performance proven **VACUUM SOLUTIONS™**

VECTOR TECHNOLOGIES LTD. AND ITS VACUUM ENGINEERING GROUP AND ROSS COOK BRANDS are leading designers and manufacturers of industrial vacuums, abrasive blast and surface preparation equipment, portable dust collectors and baghouses, asbestos and hazardous waste removal equipment, and other conveyance products for hazardous and non-hazardous material handling. Vector designs have set world standards for reliability and performance in a variety of general industrial and specialized markets. Good listening, creative ideas, expert design, quality manufacturing, extensive field tests, and overall responsiveness to customers have helped Vector maintain its position of leadership since 1977. The employees of Vector take great pride in offering dependable, long lasting world-class products at competitive prices.

Vector provides benefits far beyond building the best equipment. Experienced in-field service personnel, local support, extensive parts inventories and a 24-hour assistance line assure readily available technical support. Services include specialized system design, engineering and supplying of central manifold systems, start-up training, preventive maintenance programs, field repairs, and continuing customer education. Additionally, Vector can assist with machine financing and leasing programs.

PRODUCTS

- Central Vacuum Systems
- Mobile Industrial Vacuums
- Vacuum Excavators for Horizontal Directional Drilling
- Combination Vacuum and Jetter Systems
- Cyclonic Baghouses/ Intermediate Separators
- Dust Collectors/ Baghouses
- Abrasive Blasting/ Classifying Equipment
- Asbestos and Hazardous Waste Removal Equipment

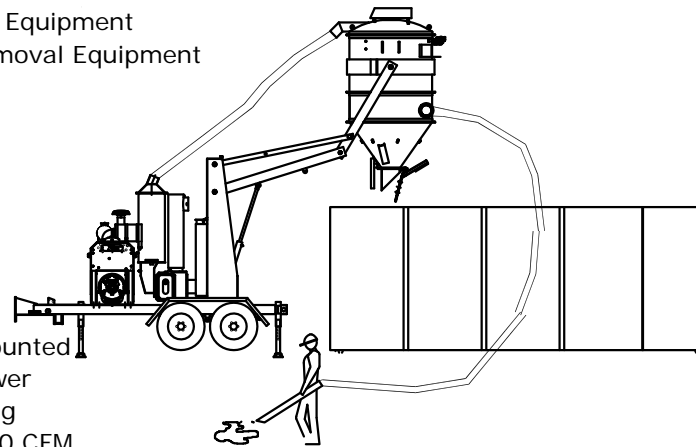
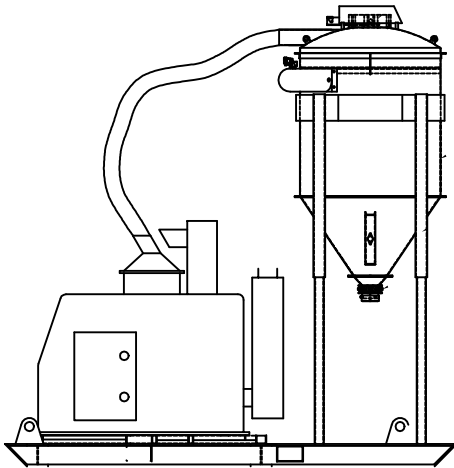

CONFIGURATIONS

- Trailer, central, skid or truck mounted
- Vacuums: 5 to 500 Horsepower
- 300 to 6,000 CFM/ to 28" Hg
- Dust Collectors: 5,000 to 60,000 CFM
- Electric, diesel, gas, and liquid propane powered

INDUSTRIES

Mining	Surface Preparation	Hydro Blasting	Steel Mills	Aerospace
Wood/Paper/Pulp	Vacuum Excavation	Power Plants	Chemicals	Clean Room
Primary Metals	Site Remediation	Shipbuilding/Repair	Glass	Powder Coating
Nuclear/Asbestos	General Industrial	Foundry	Chip & Wafer	Waste Water
Spill Recovery	Brick/Refractory	Emergency Response	Roofing	Bulk Material
Baking	Hazardous Waste	Industrial Cleaning	Cement	Plastics
Carbon	Sewer Cleaning	Railroad Car Cleaning	Catalyst	Pharmaceutical

REPRESENTATIVE CUSTOMERS

Ford Motor, Boeing, Lafarge, Northrop Grumman, Lockheed-Martin, Halliburton, Cat-Tech, General Electric, Eastman Kodak, Bechtel, Bristol Myers, IBM, General Motors, Philip Morris, Rockwell, Owens Corning, U.S. Depts. of Army, Air Force, Navy, U.S. Dept. of Energy, Boise Cascade, Carnegie Mellon, Cargil, Exxon Mobil, Hewlett Packard, International Paper, Johnson Controls, Kerr McGee, Newport News Shipbuilding, Proctor & Gamble, Lawrence Livermore, Oakridge, and Los Alamos National Labs, Textron, Tenneco, U. S. Steel, U. S. Generating, Intel, DuPont, Kerr-McGee, General Dynamics, General Mills, Kimberly-Clark, Nabisco, Pillsbury, 3M, Toyota, Honda, Xerox, Alcoa.

VECTOR TECHNOLOGIES LTD. / VACUUM ENGINEERING GROUP/ ROSS COOK BRAND

6820 North 43rd Street/ Milwaukee, WI USA

Phone: 1 414 247-7100/ Fax: 1 414 247-7110/ E-Mail: sales@vector-vacuums.com/ Website: www.vector-vacuums.com