

Ross Cook BRAND™

PERFORMANCE PROVEN



EOS Series

Ross Cook Brand Extended Overhung Series represent the simplest multi-stage exhausters and blowers available. Mounting the impellers directly on an extended motor shaft eliminates the requirement for a motor coupling and shaft alignment, while reducing required maintenance.

Performance Range
 Pressure: 0.3 to 5.0 PSIG
 Vacuum: 3.0 to 8.5 Hg
 Volume: 75 to 7000 CFM



VEC Series

VEC multi-stage exhausters and blowers for the most critical and demanding applications, or where higher pressures or vacuum levels are required. Features include cast iron housings, cast aluminum impellers, Babbitt labyrinth seals, and 10 year life bearings.

Performance Range
 Pressure: 2.0 to 13.0 PSIG
 Vacuum: 3.0 to 16.0 Hg
 Volume: 85 to 7000 CFM



Combination Units

Powerful, yet compact vacuum systems that combine the vacuum exhauster and filter separator on a common heavy-duty frame. Ross Cook Brand Combination systems are ideal for continuous-duty applications including recovery of super-fine powders; machine-scrap or dust collection, or for general housekeeping. Combination systems can support multiple hose operators, and are available in wide ranges of power and performance.



Portable Vacuum Systems

Sturdy, compact and powerful systems configured to handle most heavy-duty vacuum applications, including powders. Components are mounted on a sturdy steel frame equipped with ball bearing wheels and casters to allow for easy movement throughout your facility. Many models have built-in forklift pockets to allow for convenient pickup and transport. Extremely quiet! Electric, gas and L.P. power. Power from 3.0 – 75.0 horsepower.



Separators and Baghouses

Separators, filter-receivers and baghouses to meet a broad spectrum of customer needs. For use with Ross Cook Brand exhausters or with process systems. Available offerings include primary separators, filter-bag and filter-cartridge separators, high efficiency cyclones, liquid collection separators, water-mix separators for collecting flammable or explosive materials, and the HAZVac separator for hazardous materials.



Vacuum Hose, Tubing and Fittings

For 30 years Vector Technologies has supplied the highest quality tubing and fittings for the vacuum industry. Ross Cook Brand tubing and fittings are lightweight, strong and economical to install. Our stock includes a wide range of sizes from 2-1/8-inch to 14-inch diameter. A complete line of accessories, including flanges inlet valves, rubber sleeves, hoses, check valves, air gates and butterfly valves are inventoried.

Systems are available with multi-stage centrifugal, positive displacement, rotary vane, and regenerative vacuum producers to meet virtually all vacuum and recovery requirements.



performance proven **VACUUM SOLUTIONS™**

Toll Free 1(800) 832-4010

VECTOR TECHNOLOGIES LTD/6820 North 43rd Street /Milwaukee, Wisconsin USA 53209

Phone: 1 414 247-7100 /Fax: 1 414 247-7110

www.vector-vacuums.com / Email: sales@vector-vacuums.com

Ross Cook ^{BRAND™}

PERFORMANCE PROVEN

Central Vacuum and Conveying Systems Clean Faster and Better!

Overview From general housekeeping duties to more complicated job specific requirements, central vacuum system and conveying systems can often be the most effective method to clean facilities and convey material, regardless of consistency, weight and particle size. Central vacuums can transport and remove fine or submicron particles including powders and those found in smoke, grindings and buffing materials or larger debris such as chips, strips and pellets. Liquids, sludge, moist or wet materials can also be easily collected, removed or conveyed using a central vacuum or conveying system. System configurations can consist of single or multiple manually operated hoses and pick-up tools for general housekeeping, source-capture vacuum hoses connected to hand tools or machinery, or a combination of both. Regardless of how the system is used, the end result of a central vacuum and conveying system utilization is a cleaner, healthier and more efficient environment.

Custom Designs

Ross Cook Brand engineers design every system to meet specific customer requirements and needs. Considerations include, but are not limited to, the properties of the material to be collected, the physical environment including elevation and humidity, the size of the facility, the length of the piping runs, the number of simultaneous operators and overall customer expectations. Investment payback is also analyzed.

Less Maintenance

When compared to portable, manual or mechanical systems, central vacuum and vacuum conveying systems generally are less expensive to operate, quieter, more energy efficient, more versatile and more easily expandable. Further, a well designed vacuum system will require less maintenance and will last longer than most alternative equipment. For situations where product contamination and/or cross-contamination represent an

unacceptable condition, fine particulate can be vacuumed and removed from the cleanroom or similar sensitive area and deposited outside the area rather than reintroducing contaminated air back into it.

Main system elements

A vacuum conveying system consists of three main elements, the vacuum producer (exhauster/blower/vacuum pump), hard piping, hoses and tools to capture and convey collected particulate, and separators to collect and contain material. As illustrated in a typical system as shown below, the

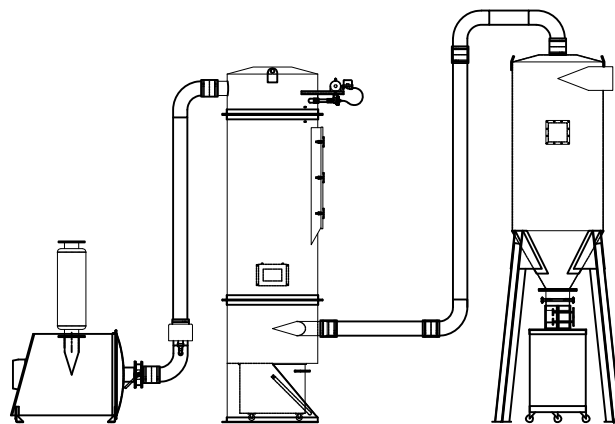

vacuum producer draws air through the entire system, pulling material through the piping system into the primary separator where the larger or heavier material is centrifugally removed from the airstream. From there the material moves into the secondary filter separator where the fine and sub-micron material is captured and collected. Finally the filtered airstream is drawn

harmlessly through the vacuum producer and the filtered air discharged back into the facility or outside to atmosphere. Dependent upon the properties of the material being conveyed the primary separator and the filter separator can be combined into what is often referred to as a cyclonic baghouse where the separation and the filtering of the airstream is accomplished within a single component.

Special Applications are Our Specialty.

Each Ross Cook Brand vacuum conveying system is designed to meet all special needs from the material handling capabilities to the tools required to make the job as efficient as reasonably possible. Whether the application is wet, dry, sticky, corrosive, abrasive, toxic, hazardous, explosive, hygroscopic, combustible, extremely hot, extremely cold, or a special capture hood or tool design is required, a Ross Cook Brand or Vector Technologies system can be designed to meet your needs and expectations.

Performance Proven Central Vacuum Systems

VACUUM PRODUCERS The typical vacuum producer for central vacuum systems with multiple users are Multistage Centrifugal Exhausters. Operating at 3500 RPM, Multistage Centrifugal Exhausters are designed to provide efficient, long-lasting, quiet, continuous and dependable operation with little or no maintenance. Ross Cook Brand offers two types of Multistage Centrifugal Exhausters: the EOS- Extended Overhung Series, a compact workhorse, and the VEC Series, for more demanding jobs. Positive displacement and alternative vacuum producers are additionally offered for varied applications.

SEPARATORS Separators (also know as baghouses, cyclones, collectors, product receivers, etc.), separate material from an incoming air stream. Separators can be designed for a wide variety of applications, ranging from bulk material handling to removing submicron particulate from the airstream. Vector Technologies and Ross Cook Brand design and manufacture several different types of separators.

Filter Separator (Baghouse) Utilizes application-specific tubular filter bags or pleated filter cartridges to capture smaller material and fines, often in conjunction with a centrifugal primary separator. When fine granular or pulverized materials or powders are being conveyed, a filter separator is generally required for complete separation as well as protection of the vacuum producer which would be jeopardized if material passed though it. Filters can be self-cleaning, using mechanical shaking or reverse pulse-jet air technology, or manually cleaned with a built-in Bag Shaker.

Centrifugal Separator (Primary) Generally used as a primary product receiver. The separator uses centrifugal force and gravity to spin large particles out of the airstream. The separated material drops out of the airstream and collects in the bottom of a conical hopper for removal from the system. For dust-free material a primary separator can be used as a stand alone separator without filtration.

High Efficiency Cyclone Used for conveying extremely fine materials, such as dust or powder, where maximum percentage particle separation is desirable

Wet Separator Used in liquid conveying applications or where the material has a high moisture content to drop out material from the airstream.

HAZVac Separator Used when recovering hazardous materials or for use when the environment must be protected from potential contamination. Ross Cook Brand's bag-in/bag-out separation technology offers proven protection.

PIPING Central vacuum systems collect material from specific points in a facility. Piping extends from the vacuum producer, often located outside the building, to the most distant point of use. Piping systems are engineered according to how many inlets or pickup points will be used simultaneously, the characteristics of the material being conveyed, and how far the collected material must travel. Further consideration is given to altitude, humidity and ambient temperature of the facility. Piping is then sized accordingly with further consideration to horizontal runs, bends, sweeps, vertical rises, falls and friction loss.

ACCESSORIES Accessories are used to enhance a vacuum conveying system or upgrade it to meet specifically engineered requirements. Typical accessories may include, but are not limited to:

- Integrated process control panels
- Inlet and discharge silencers and filters
- Surge control to prevent vacuum producer cavitation
- Level sensors to monitor fill levels of separator and hoppers
- Butterfly, check, diverter, or gate valves to control or redirect airflow
- Airlocks, double tipping valves and screw conveyors to continuously remove collected material
- Explosion venting and suppression systems
- Vacuum Hose and Tools

APPLICATIONS How a central vacuum system might benefit your operation is limited only by your imagination. Here are a few examples of where Ross Cook Brand customers are currently using their central vacuum systems:

- Removing flammable fumes from ship holds
- Fly ash removal
- Clean up around CNC machines
- Facilities housekeeping
- Cleaning multiple process lines on co-packing lines
- Bag-in/Bag-out system inside a Class 100 clean room

INDUSTRIES Industries using central vacuums include:

- Aerospace • Bottlers • Fiberglass • Grain •Metal Working
- Medical •Pharmaceutical •Shipping •Petrochemical
- Mining •Car Wash •Agriculture •Dental •Machining
- Semiconductor •Food Processing •Hotel •Milling
- Waste Treatment •Woodworking •Furniture •Textile
- Auto Body Shop •Shipyard •Pulp and Paper •Cement
- Textile • Power •Carbon •Glass •General Industrial

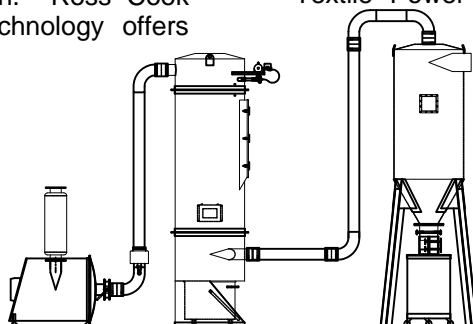

Vacuum Pipe, Tubing, Hose and Tools For Better Results, Faster!

Central Piping System Components

Vector Technologies and Ross Cook Brand offers a full range of Central vacuum components and related products including tubing, pipe, bends, compression couplings, fittings and other installation essentials. Standard tube and pipe components are available in carbon, galvanized and stainless steel, as well as aluminum. We offer superior quality at competitive pricing.



Hose, Tools and Accessories

Vector Technologies and Ross Cook Brand offers a full range of vacuum hose, tools and accessories for all vacuum cleaning systems. Inventoried hose and tools range from light-weight hose and tools for plant central vacuum systems to heavy-duty abrasive resistant hose and tools for specific job needs. Diameters range from 1.5" to 8". Each has been developed with customer input and over 30 years of on-the-job and in-field experience. All items are industrial duty, each having been developed for long term operator comfort with a focus towards increased safety, production and efficiency. Even the lighter weight tool designs have replaceable wear surfaces. Our inventory includes vacuum hoses in various diameters and materials, plus cleaning wands, wall and floor tools, inlet valves, hose racks, couplings and vacuum tools for varied cleaning activities of wet and dry products.





performance proven **VACUUM SOLUTIONS™**

Other Vacuum Products from Vector Technologies!



Trailer-mounted or Skid-Mounted Cyclones & Baghouses

Hoppers for combining with vac trucks for loading caustics or abrasives, bulk product, contaminated materials, or into roll-offs, bulk bags or onto conveyors.



VecLoader® Titan Series Mini-VecLoader Series To 5,600 CFM and 28" Hg.

Versatile wet/dry trailered vacuums with the power and performance of a vacuum truck at a fraction of the capital and maintenance cost.



Skid-Mounted Cyclones & Baghouses

Cyclonic Baghouses and Separators to match to existing vacuum systems or as a companion module to PM Power Modules or other blower packages.



VecLoader Spartan® Series

Compact and powerful vacuums. Unique design allows loading into hoppers, drums, or other collection devices.



HydroVacs and Specialized Systems

To 3,600 CFM and 28" Hg.



Intermediate Separators

Vector offers a wide range of drum fillers, self-dumping hoppers and intermediate separators for varied collection options.



Systems for Use with Vac Trucks

Easily transportable hoppers, baghouses, classifiers, HEPA filter banks and other modules to enhance the versatility of vacuum trucks.



PM™ Power Modules

Quiet Power Modules to match to cyclonic baghouses, separators or other collection devices. Compact power and performance with conveyance capabilities to 5,600 CFM/28" Hg.



CST™ Series Vacuum Systems

Self-contained portable vacuum systems. Load into dumpsters, gaylords, processing systems and conveyors. Power ranges from 25 to 300 Hp and to 3700 CFM/28" Hg.

VECTOR TECHNOLOGIES LTD/6820 North 43rd Street /Milwaukee, Wisconsin USA 53209

Toll Free: 1 800 832-4010 Phone: 1 414 247-7100 /Fax: 1 414 247-7110

www.vector-vacuums.com / Email: sales@vector-vacuums.com

Toll Free 1(800) 832 4010

Vacuums · Hydro Blast Systems · Dust Collectors · Vacuum Excavation Systems · Classifiers
Blast and Recovery Systems · Vacuum/Jetter Combinations · Spill Response Systems
Equipment · Parts · Rentals · Service · Solutions



VECTOR TECHNOLOGIES LTD., AND ITS VACUUM ENGINEERING GROUP are leading designers and manufacturers of mobile, portable, and central vacuums, abrasive blasting and surface preparation equipment, portable dust collectors and baghouses, asbestos and hazardous waste removal equipment, and other conveyance products for hazardous and non-hazardous material handling. For over thirty years, Vector designs have set world standards for reliability and performance in a variety of industrialized and specialized markets. With good listening, creative ideas, expert design, quality manufacturing, extensive field tests, and responsive service, Vector maintains its position of leadership. The employees of Vector take great pride in offering dependable, long lasting world-class products at competitive prices.

Vector provides advantages and benefits that far exceed building the best equipment. Experienced in-field service personnel, an extensive parts inventory, and a 24-hour assistance line assure readily available technical support. Vector services include engineering and supplying of central manifold systems, start-up and training, preventive maintenance programs, field repairs, continuing customer education, machine rentals, and leasing programs.

PRODUCTS

- Central Vacuum Systems
- Mobile Industrial Vacuums
- Portable Vacuums
- Vacuum Excavators for Horizontal Directional Drilling
- Combination Vacuum and Jetter Systems
- Cyclonic Baghouses/ Intermediate Separators
- Dust Collectors/ Baghouses
- Abrasive Blasting/ Classifying Equipment
- Asbestos and Hazardous Waste Removal Equipment
- Tubing, Fittings, Hose and Accessories

Ross Cook Brand™, VecLoader Spartan® , VecLoader Titan® , Mini VecLoader, VecLoader Hepa Vac® , PM™ Series, CS™ Series, HDD™ Series, Neptune™ Series, BH™ Series, IS™ Series, Titan Combo™ , Titan Klean Shot® , Hercules™, MDC™ Dust Collectors, Rapid Response™ Series, Invader® , Flex 4® , InsulEater®

CONFIGURATIONS

- Trailer, central, skid, or truck mounted
- Vacuums: 3 to 500 Horsepower
- 100 to 6,000 CFM/ to 28” Hg
- Dust Collectors: 5,000 to 60,000 CFM
- Electric, diesel, gas, and liquid propane powered

INDUSTRIES

Roofing	Surface Preparation	Hydro Blasting	Steel Mills
Wood/Paper/Pulp	Vacuum Excavation	Power Plants	Chemicals
Primary Metals	Semiconductor	Shipbuilding/Repair	Glass
Nuclear/Asbestos	Industrial Vacuum Cleaning	General Industrial	Food & Pharmaceutical
Aerospace	Brick/Refractory	Foundry	Minerals
Petrochemical	Hazardous Waste	Waste Water	Cement
Carbon	Sewer Cleaning	Railroad Car Cleaning	Catalyst

REPRESENTATIVE CUSTOMERS

Ford, Boeing, IBM, Lockheed-Martin, Halliburton, Pfizer, Intel, Eastman Kodak, Bechtel, Bristol Myers, Toyota, Honeywell, Rockwell International, Nabisco, U.S. Depts. of Army; Air Force; Navy; U.S. Dept. of Energy, Lafarge Cement, Carnegie Mellon, Cargill, Exxon, Hewlett Packard, International Paper, Johnson Controls, Kerr McGee, Newport News Shipbuilding, Proctor & Gamble, Los Alamos and Lawrence Livermore National Labs, Textron, Tenneco, U. S. Steel, U. S. Generating, Mobil, General Dynamics, General Motors

VECTOR TECHNOLOGIES LTD/6820 North 43rd Street /Milwaukee, Wisconsin USA 53209
Toll Free: 1 800 832-4010 Phone: 1 414 247-7100 /Fax: 1 414 247-7110
www.vector-vacuums.com / Email: sales@vector-vacuums.com

**Vacuums · Hydro Blast Systems · Dust Collectors · Vacuum Excavation Systems · Classifiers
 Blast and Recovery Systems · Vacuum /Jetter Combinations · Spill Response Systems
 Equipment · Parts · Rentals · Service · Solutions**