



performance proven **VACUUM SOLUTIONS™**

# Vac Attack!

PM Series Vacuum Systems are versatile, skid-mounted industrial vacuums that combine two components; a skid mounted PM Power Module matched to a BH™ series cyclonic baghouse or alternative collection device. Components are directly connected through rigid and/or flexible pipe. Units can recover most flowable bulk materials and liquids for discharge directly back into the production system or into varied disposal or interim containers. Power modules are offered in electric or diesel power and can be utilized as vacuum producers for stand-alone vacuums or in paired to process equipment or to central piping. Sound levels of under 85 dBA are obtainable on many electric units by adding optional sound attenuation enclosures and premium grade silencers.



**PM Series Power Module (Vertical)  
Model PM 2400/23, 75 Hp Shown  
(Shown with crane-lift package)**

## PM™ SERIES VACUUM SYSTEMS

**BH™ Series Cyclonic Baghouses**



**PM Series Power Module  
Model PM 2400/28, 170 Hp Shown  
(RB sound enclosure package)**



**BH™ Series Cyclonic Baghouse  
Model BH 54" Shown  
With optional catwalk**

**PM Series Power Module  
Matched with  
BH™ Series Cyclonic Baghouse**

**Maximum Power And  
Performance In Versatile,  
Rugged Designs.**



**BH™ Series Cyclonic Baghouse  
Model BH 54" Shown  
With Manual Dump Valve**

**Ultimate Flexibility Offered!**

Combine PM Power Modules with a BH Series Baghouse or other Collection Module  
Combine BH Series Baghouses with a PM Series Power Module or other Vacuum Source.

Vector Technologies Ltd./ Vacuum Engineering Division/ 6820 N. 43<sup>rd</sup> Street/ Milwaukee WI USA 53209

Toll Free: 1 800 832 4010/ Tel: 1 414 247 7100/ Fax: 1 414 247 7110

Web Site: [www.vector-vacuums.com/](http://www.vector-vacuums.com/) E-Mail: [sales@vector-vacuums.com](mailto:sales@vector-vacuums.com)

## **PM™ Series Power Module Stationary and Central Vacuum Systems**



The motor or engine coupled with a Roots style positive displacement blower is driven by a multiple V-belt or direct drive. A vacuum breaker is provided as part of the dump cycle control. An absorption silencer is attached to the blower discharge for sound suppression.

The Power module is fitted with a product specific cartridge filter in a microfilter housing for protection on the clean air side of the baghouse. This filter achieves 99.90% efficiency for particulate 0.5 micron or larger and provides secondary filtration and blower protection. The filter housing is fitted with a magnehelic gauge to show the pressure drop across the filter.

All required safety guarding is included in the standard package. Enclosures with locking latches are available as options to cover operating components for added environmental protection, safety and noise suppression.

The Power module is set on a mounting platform for permanent installation. A heavy duty skid with fork lift pockets and lifting eyes is optionally available for system mobility. Modules are painted with weather resistant paint and where appropriate, components are primed and painted before final assembly to enhance resistance to corrosion.

Power modules can be equipped with customer specified control panels, explosion proof motors, diesel power, remote operator controls, trailer mounting, sound attenuation, high temperature packages, and fiberglass enclosures.

**BH™ Series Cyclonic baghouses/collector devices--** Modules are set on legs at customer designated heights and matched to specific Power Modules filtration and unload requirements. Units feature tangential inlets, deflector plates, removable wear plates, pulsed-cleaned Teflon coated filters, plus magnehelic gauges for filter monitoring. Available options include stainless steel cylinders and cones, explosion venting, special unloader valves, high temperature packages, hydraulically raised legs, sloped cones, air cannons, augers or other discharge enhancements, and special coatings for corrosive materials.

**PM™ Power Module Series Vacuums and BH™ Series Cyclonic Baghouses** are modular in design and can be easily matched to a wide assortment of available options.



performance proven **VACUUM SOLUTIONS™**



## PM™ Series Power Modules

### Stationary and Central Vacuum Systems

PM™ Series Vacuum Systems are versatile, electric or diesel, skid-mounted industrial vacuums that combine two components; a skid mounted PM Series Power module matched to a BH™ series cyclonic baghouse or alternative collection device. Components are directly connected through rigid and/or flexible pipe. Units can be used for vacuuming most flowable bulk materials and liquids for discharge directly back into the production system or into disposal or interim containers. Power modules can be used as vacuum producers for stand-alone vacuums or in conjunction with process equipment and central piping systems. The PM series features the rugged construction, quality, and powerful performance of all Vector products.

### PM™ Series Power Modules (Production in U.S. Tons)

<u>Standard Models</u>	<u>Inlet Size (Inches)</u>	<u>Max CFM</u>	<u>Max HG</u>	<u>Productivity Tons/Hour</u>	<u>Gallons/Min</u>	<u>3 Phase H. P.</u>	<u>Distance Feet</u>
PM 700/16	3"	659	16"	2-4	50	25	600'
PM 1400/16	4"	1,337	16"	3-4	100	50	600'
PM 1400/23	4"	1,337	24"	4-5	100	75	800'
PM 1400/28	4"	1,337	28"	4-5	100	100	1,200'
PM 2000/16	4"	1,972	16"	8-10	150	75	600'
PM 2400/16	5"	2,367	16"	10-12	200	100	600'
PM 2400/28	5"	2,367	28"	10-20	200	150	1,200'
PM 3700/16	6"	3,658	16"	16-20	300	125	600'
PM 3700/28	6"	3,658	28"	15-19	300	250	1,200'
PM 4200/16	6"	4,156	16"	18-23	350	175	600'
PM 4100/28	6"	4,068	28"	20-24	350	250	1,200'
PM 4800/16	6"	4,800	16"	20-24	350	200	600'
PM 6200/16	8"	6,233	16"	25-30	550	250	600'
PM 5900/28	8"	5,910	28"	25-30	500	400	1,200'
PM 11000/28	12"	11,010	28"	40-50	900	500	1,200''

Note that the above performance is based upon standard conditions with easily conveyed products at shorter distances. Other conditions, including product, hose diameter and length, elevation and temperature may significantly impact system efficiency and performance.

**Power module--** Module contains the motor, blower, blower protection, and the main control panel. It is skid mounted on a heavy-duty structural steel frame and powered by a 3 phase, 60Hz motor. A combination circuit breaker starter is contained in a NEMA 12 enclosure (NEMA 4, 4x and 7 are available). Controls and instruments include a master disconnect, blower-on switch, baghouse-on switch, vacuum on switch, pilot lights, emergency stop button and hour meter located on the panel cover. Solid-state controls regulate hopper unload functions.

**BH™ Series Cyclonic baghouses/collector devices--** Modules are set on legs at customer designated heights and matched to specific Power Modules filtration and unload requirements. Units feature tangential inlets, deflector plates, removable wear plates, pulsed-cleaned Teflon coated filters, plus magnehelic gauges for filter monitoring. Available options include stainless steel cylinders and cones, explosion venting, special unloader valves, high temperature packages, hydraulically raised legs, sloped cones, air cannons, augers or other discharge enhancements, and special coatings for corrosive materials.

Vector Technologies Ltd./ Vacuum Engineering Division/ Ross Cook Brand/ 6820 N. 43<sup>rd</sup> Street/ Milwaukee WI USA 53209

Toll Free: 1 800 832 4010/ Tel: 1 414 247 7100/ Fax: 1 414 247 7110  
 Web Site: [www.vector-vacuums.com/](http://www.vector-vacuums.com/) E-Mail: [sales@vector-vacuums.com](mailto:sales@vector-vacuums.com)

1. ALL DIMENSIONS SHOWN ARE IN INCHES.  
 NOTES: UNLESS OTHERWISE SPECIFIED

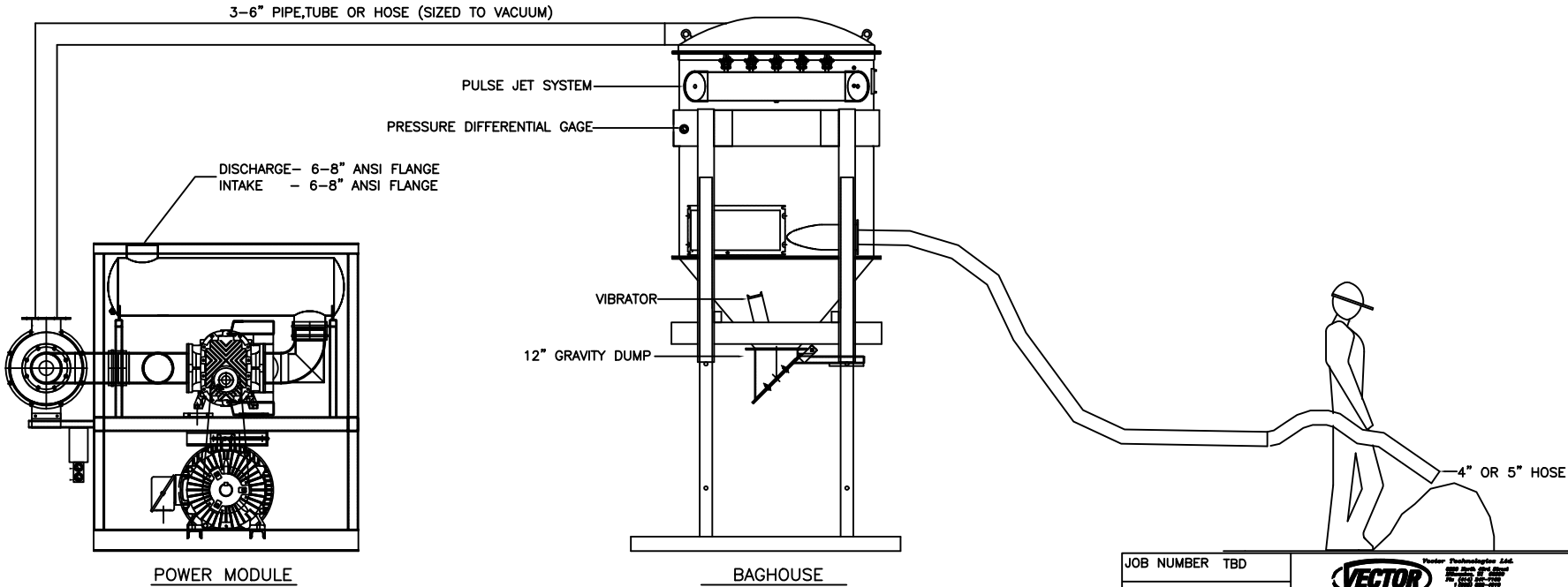

JOB NUMBER TBD

APPROVALS	DATE
DESIGN B. REAVIS	9-18-07
CHECKED B. REAVIS	9-18-07
ENGR B. REAVIS	9-18-07
REV. 0	

**PROPRIETARY INFORMATION**  
 THIS DRAWING IS THE PROPERTY OF VECTOR TECHNOLOGIES, LTD. ("VECTOR"). IT MUST NOT BE TRADED, COPIED, OR REPRODUCED IN ANY MANNER, NOR SHALL IT BE LOANED OR SUBMITTED TO OTHERS FOR EXAMINATION WITHOUT THE CONSENT OF VECTOR. IT SHALL BE USED ONLY AS A MEANS OF REFERENCE TO WORK DESIGNED OR FURNISHED BY VECTOR.

**VECTOR** Vector Technologies Ltd.  
100 York Street  
London, Ontario N6A 1K1

**Ross & Cook**  
performance proven VACUUM SOLUTIONS™

**POWER MODULE AND BAGHOUSE GENERAL ARRANGEMENT**

SIZE: D    CASE CODE:    ENG. NO.: NGPID    REV.:

SCALE: X/X    COLD BY: ACT BY:    SHEET 1 OF 1