



performance proven VACUUM SOLUTIONS™

Vac Attack!

HIGH-POWERED INDUSTRIAL VACUUMS AND VACUUM LOADERS



Trailer-mounted or Skid-Mounted Cyclones & Baghouses

Hoppers for combining with vac trucks for loading caustics or abrasives, bulk product, contaminated materials, or into roll-offs, bulk bags or onto conveyors.



VecLoader® Titan Series Mini-VecLoader Series To 5,600 CFM and 28" Hg.

Versatile wet/dry trailer-mounted vacuums with the power and performance of a vacuum truck at a fraction of the capital and maintenance cost.



Skid-Mounted Cyclones & Baghouses

Cyclonic Baghouses and Separators to match to existing vacuum systems or as a companion module to PM Power Modules or other blower packages.



VecLoader Spartan® Series

Compact and powerful vacuums. Unique design allows loading into hoppers, drums, or other collection devices.



HydroVacs and Specialized Systems To 3,600 CFM and 28" Hg.



Intermediate Separators

Vector offers a wide range of drum fillers, self-dumping hoppers and intermediate separators for varied collection options.



Systems for Use with Vac Trucks

Easily transportable hoppers, baghouses, classifiers, HEPA filter banks and other modules to enhance the versatility of vacuum trucks.



PM™ Power Modules

Quiet Power Modules to match to cyclonic baghouses, separators or other collection devices. Compact power and performance with conveyance capabilities to 5,600 CFM/28" Hg.



CST™ Series Vacuum Systems

Self-contained portable vacuum systems. Load into dumpsters, gaylords, processing systems and conveyors. Power ranges from 25 to 300 Hp and to 3700 CFM/28" Hg.

Vector Technologies Ltd./ Vacuum Engineering Division/ 6820 N. 43rd Street/ Milwaukee WI USA 53209

U.S. Toll Free: 1.800.832.4010/ Phone: 1.414.247.7100/ Fax: 1.414.247.7110

Web Site: www.vector-vacuums.com/ E-Mail: sales@vector-vacuums.com

U.S. Toll Free 1(800) 832 4010

Vacuums · Hydro Blast Systems · Dust Collectors · Vacuum Excavation Systems · Blast and Recovery Systems · Spill Response Systems
Equipment · Parts · Rentals · Service · Solutions



performance proven **VACUUM SOLUTIONS™**

VECTOR TECHNOLOGIES LTD. AND ITS VACUUM ENGINEERING GROUP AND ROSS COOK BRANDS

are leading designers and manufacturers of industrial vacuums, abrasive blasting and surface preparation equipment, portable dust collectors and baghouses, asbestos and hazardous waste removal equipment, and other conveyance products for hazardous and non-hazardous material handling. Established in 1977, Vector designs have set world standards for reliability and performance in a variety of industrialized and specialized markets. With good listening, creative ideas, expert design, quality manufacturing, extensive field tests, and responsive service, Vector maintains its position of leadership. The employees of Vector take great pride in offering dependable, long lasting world-class products at competitive prices.

Vector provides benefits far beyond building the best equipment. Experienced in-field service personnel, extensive parts inventories and a 24-hour assistance line assure readily available technical support. Services include specialized system design, engineering and supplying of central manifold systems, start-up training, preventive maintenance programs, field repairs, and continuing customer education. Additionally, Vector can assist with machine financing and leasing programs.

PRODUCTS

- Central Vacuum Systems
- Mobile Industrial Vacuums
- Vacuum Excavators for Horizontal Directional Drilling
- Combination Vacuum and Jetter Systems
- Cyclonic Baghouses/ Intermediate Separators
- Dust Collectors/ Baghouses
- Abrasive Blasting/ Classifying Equipment
- Asbestos and Hazardous Waste Removal Equipment

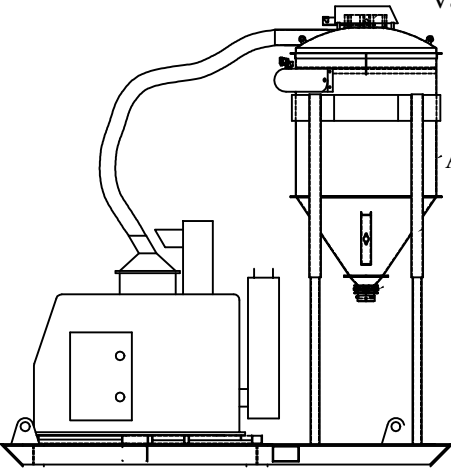

CONFIGURATIONS

- Trailer, central, skid or truck mounted
- Vacuums: 5 to 500 Horsepower
- 300 to 6,000 CFM/ to 28" Hg
- Dust Collectors: 5,000 to 60,000 CFM
- Electric, diesel, gas, and liquid propane powered

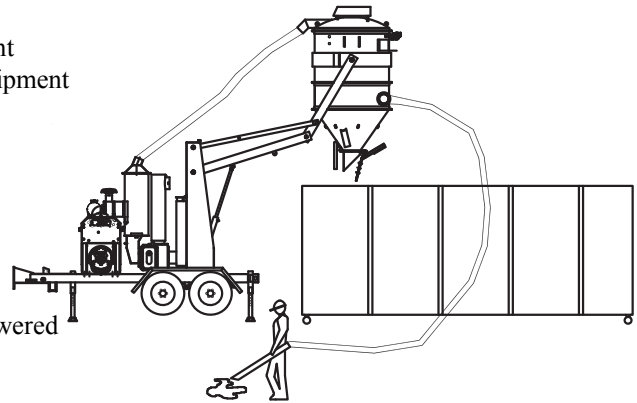

INDUSTRIES

Mining	Surface Preparation	Hydro Blasting	Steel Mills	Aerospace
Wood/Paper/Pulp	Vacuum Excavation	Power Plants	Chemicals	Clean Room
Primary Metals	Site Remediation	Shipbuilding/Repair	Glass	Powder Coating
Nuclear/Asbestos	Industrial Vacuum Cleaning	General Industrial	Foundry	Chip & Wafer
Spill Recovery	Brick/Refractory	Emergency Response	Roofing	Oil & Gas
Bulk Material	Hazardous Waste	Waste Water	Cement	Plastics
Carbon	Sewer Cleaning	Railroad Car Cleaning	Catalyst	Pharmaceutical

REPRESENTATIVE CUSTOMERS

Ford Motor, Boeing, Northrop Grumman, Lockheed-Martin, Halliburton, Cat-Spec, General Electric, Dupont, Eastman Kodak, Bechtel, Bristol Myers, IBM, General Motors, Philip Morris, Rockwell International, Owens Corning, U.S. Depts. of Army, Air Force, Navy, U.S. Dept. of Energy, Boise Cascade, Carnegie Mellon, Cargil, Exxon, Hewlett Packard, International Paper, Johnson Controls, Kerr McGee, Newport News Shipbuilding, Proctor & Gamble, Lawrence Livermore, Oakridge, and Los Alamos National Labs, Textron, Tenneco, U. S. Steel, U. S. Generating, Kerr-McGee, General Dynamics, Dupont, General Mills, Kimberly-Clark, Nabisco, Pillsbury, 3M, Toyota, Honda, Xerox, Alcoa.

VECTOR TECHNOLOGIES LTD. / VACUUM ENGINEERING GROUP/ ROSS COOK BRAND

6820 North 43rd Street/ Milwaukee, WI USA

Toll Free: 1 800 832-4010/ Phone: 1 414 247-7100

Fax: 1 414 247-7110/ E-Mail: sales@vector-vacuums.com/ Website: www.vector-vacuums.com